

Drainex 100 Drainage



Submersible pumps, Vortex system

Applications

Drainage of sewage and dirty water, operation in septic tanks and small purifying installations.

Materials

Discharge body and upper mounting in cast iron.
Impeller in brass with free passage of particles in suspension of \varnothing 34mm.
Double mechanical seal in ceramic/graphite and ceramic/silicon carbide.
Motor housing and transport handle in stainless steel AISI 304.

Motor

Asynchronous, two poles.
IP 68 protection.
Class F insulation.
Continuous operation.
Single-phase version built-in thermal protection.

Drainex 100 A: supplied built-in float switch.

Equipment

Supplied with 10m power cable.
Single-phase supplied with capacitor box.

Limitations

Maximum solids handling: 32mm.
Maximum immersion: 8m.
Maximum liquid temperature: 40°C.

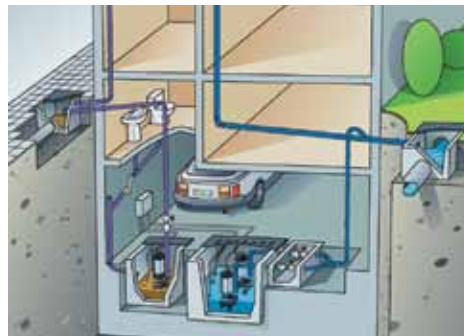

Dimensions and weights

Model	A	B	C	D	Kg
Drainex 100	270	485	295	1 1/4"	23

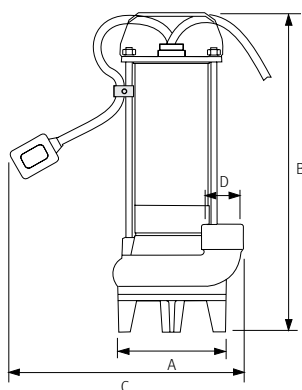

Performance curves at 2900 rpm

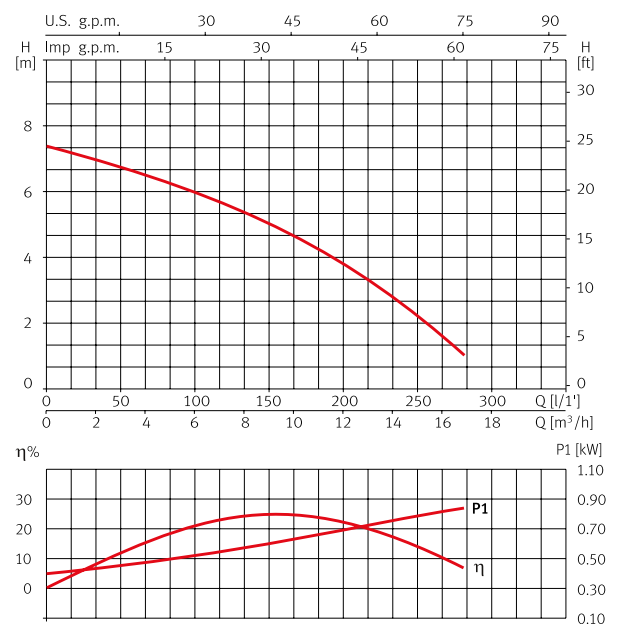

Hydraulic performance table

Model	I (A)	P1 (kW)	P2		μF	Flow Rate								
	1~230 V	1~	(kW)	(HP)		l/min	25	50	100	125	150	200	250	280
Drainex 100 M	3,4	0,75	0,75	1	12	m³/h	1,5	3,0	6,0	7,5	9,0	12	15	16,8
						mwc	7	6,7	5,9	5,5	5	3,7	2	1